

SailboatsToGo
978 263 7598
Jim@SailboatsToGo.com

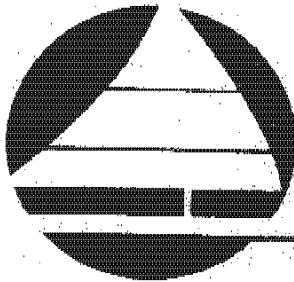

SNARK BOATS

OWNERS MANUAL

MODELS: SB102 and SB114

- Safety
- Assembly
- Operation
- Transportation
- Maintenance
- Replacement Parts

SPECIFICATIONS

Length	11'	Freeboard	12'
Beam	38"	Sail Area	45 sq. ft.

NOTICE

*Do not allow raw gasoline or other petroleum based products to come in contact with styrene (core of hull).

IMPORTANT

OWNER'S RESPONSIBILITY

BE SURE TO READ THE FOLLOWING BEFORE LAUNCHING YOUR SAILBOAT

- Before operating your boat, read the Sailing Manual carefully and be thoroughly familiar with the rules for safe operation.
- Do not overload your boat. Capacities are clearly stated on the Capacity Information Plate located on the mast seat of the boat.
- The Snark is a small boat and caution must always be used, particularly when operating on open bodies of water where conditions can be unexpectedly severe.
- Always carry a Coast Guard approved personal flotation device for each person aboard and check with local authorities for regulations governing registration and operation of your boat. If capsizing should occur, stay with your boat until help arrives. It will not sink and it is far easier for rescuers to see than a lone swimmer.
- Transporting any boat on a cartop rack places considerable stress on the hull unless properly supported. Care must be used in adjusting straps, cables and clamps to prevent excessive pressure on the boat. The boat should rest inverted on its gunwales. Padding should be placed between the gunwales and the cartop carrier to prevent chaffing. In addition to securing the boat to the cartop carrier, the bow and stern should be secured to the vehicle to prevent longitudinal movement.
- To minimize needless wear and excessive scratching avoid dragging your boat over abrasive surfaces such as concrete launching ramps, coral or rocky beaches, garage floors, etc.
- Cleaning your Snark is easily accomplished with soap and water and a brush. Avoid strong detergents, alkalis and organic solvents. Suntan oils, cosmetics, and grease should be removed promptly to avoid permanent stains.

ASSEMBLY

1. RUDDER AND TILLER

- a. Locate the following items in the accessory parts box;
 1. Black rudder head (14)
 2. Aluminum rudder "L" pin (6) and hairpin type cotter pin (13)
 3. Tiller (4)
 4. 10-32 x 1" long hexbolt and locknut (29)
 5. Rudder Blade (3)
 6. 5/16" carriage bolt, washer and nut (15)
- b. Place the black rudder head (14) on the hinge plate (17) with the pointed end up. Secure in position by sliding the rudder "L" pin (6) through the flanges. Insert the hairpin through the small hole in the lower end of the "L" pin.
- c. Slide the tiller mount (4) over the pointed end of the rudder head (14) and align the upper most hole in the tiller mount with the hole in the top of the rudder head. Secure with 1" bolt and locking nut (29).
- d. Insert the carriage bolt (15) through the square hole in the center of the rudder head. This bolt must pass from the left side to the right side. Install the rudder blade (3) with 5/16" washer and locknut.
- e. Install rudder blade (3) on the carriage bolt and secure with locknut. The nut should only be tight enough to give a slight resistance when you try to lift the blade.

2. BOW EYE

- a. Insert the bow eye (7) through the predrilled hole in the bow (front) of the hull and sandwich the hull with large washers and nut.

3. SPLASH DECK—Optional (for Armor-Clad boats only)

- a. Locate mast sleeve (8) from parts box.
- b. Position splash deck (28) on the bow so that hole in wood seat and hole in deck lines up and point of deck lines up with point of boat.
- c. Insert sleeve (8) through splash deck and mast seat (5) and into mast seat.
- d. Install cleat (21) on right side of mast sleeve, using 1 1/2" long slotted machine screws, flat washers and nuts through predrilled holes in splash deck and mast seat (5).
- e. Parts for splash deck are packed in a separate bag. They consist of screws, washers and a punch nail. Align the front of the splash deck with the center of the bow, starting with the two aft (rear) holes first. Make a small starter hole with a punch nail and secure the deck with a screw and finishing washer. Repeat this procedure on all other predrilled holes in the splash deck. **NOTE:** To assure good installation, it is important that you **do not** over tighten the screws securing the splash deck.

4. SAIL ASSEMBLY

- a. Lay out the sail (12), boom and spar as shown in figure.
- b. Starting at the "clew" (rear part of the sail, closest to the boom) insert the forward end of the boom (end with predrilled holes through both sides) into the hem of the sail and slide it all the way through the sail.
- c. Position the boom guide (20) over the two predrilled holes in the forward end of the boom. Secure with two 3/4" long slotted sheet metal screws. Make sure boom guide is facing starboard (right) side of the boom.
- d. Starting at the "head" (top part of the sail) insert the lower end of the spar (end with predrilled holes through both sides) into sail hem and slide it through entire sail.
- e. Connect boom and spar with 2" long slotted bolt, washer and nut. This is the "tack" of the sail.
- f. Using eyestraps (18) and 1/2" long slotted sheet metal screws, install plastic rings (19) on boom at points "A" and "B" as shown in figure.
- g. Using sheet metal screws, install eyestraps (18) on spar at points "D" and "C" as shown in figure.
- h. There are short lengths of line attached to grommets at each corner of the sail. Tie the "head" and the "clew" to the eyestraps at points "D" and "A". Tie the "tack" to the connecting bolt of the boom and spar.

5. RIGGING

- a. Place the mast cap (22) on one end of the mast (9).
- b. Lay the folded sail assembly along the centerline of the hull so the boom guide (20) is centered over the mast sleeve (8).
- c. Locate the line supplied with the boat. Cut this line in half and seal the ends with a match or other flame. Allow the ends to cool before touching. Pass one end through eyestrap "C" and tie around spar (not around eyestrap). Pass the other end through the mast cap (22) and tie a knot as close as possible to the end.
- d. Insert the mast (9) through the boom guide (20) and into the mast sleeve, insuring that the boom is to the port (left) side of the mast.
- e. Pull down on the line (halyard sheet) (16) to raise the sail. Raise the sail as high as possible, then tie the line (halyard) around the cleat (21) at the right of the mast.

- f. Locate the remaining half of the line supplied with the boat for the main sheet. Tie one end of the main sheet line to the eyestay preinstalled on the tiller mount (4).
- g. Thread the free end through ring "A" on the base of the boom nearest the stern of the boat, then through ring "B" nearest the mast. Tie a figure "8" knot at the end of the line.
- h. Insert the daggerboard (2) into the daggerboard well.
- i. Now read your Sailing Manual and enjoy your Snark.

TRANSPORTING YOUR SAILBOAT

Transporting any boat on a cartop carrier places considerable stress on the hull unless properly supported. Care must be used in adjusting straps, cables, and clamps to prevent excessive pressure on the boat. If cartop is not wide enough, a board such as 2 x 4 across carrier could provide a good boat support and place to tie spar (mast & boom) when transporting.

The boat should rest inverted on its gunwales. Padding may be placed between the gunwales and the cartop carrier to prevent chaffing. In addition to securing the boat to the cartop carrier, the bow and stern should be tied to prevent sway or other move-

MAINTENANCE

YOUR BOAT: Your boat should be kept inside or covered when not in use. Avoid long periods of exposure to direct sunlight or weather. To minimize needless wear and excessive scratching, avoid dragging your boat over abrasive surfaces such as concrete launching ramps, coral, rocky beaches, garage floors, etc.

CAUTION: If the ABS skin is fractured and the EPS foam core exposed, gasoline or oil spillage will cause damage. Repairs to the exposed area should be made immediately using the Epoxy Repair Kit available from Snark Boats.

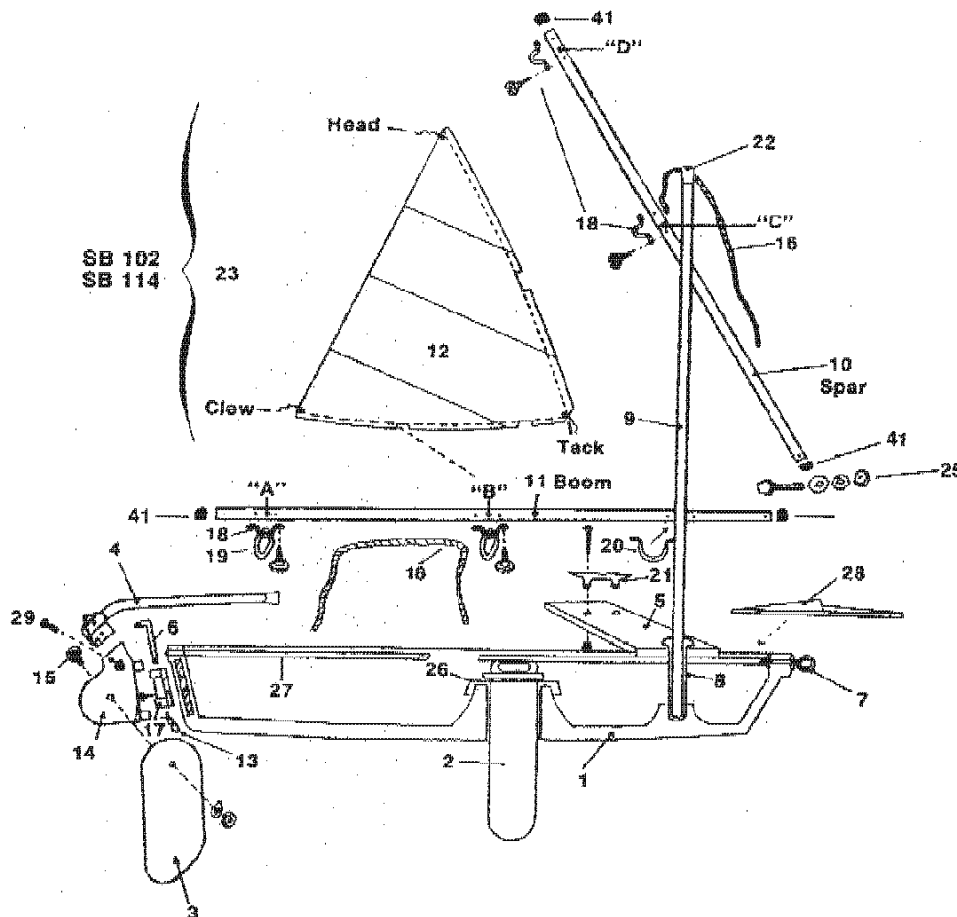

Replacement Parts Price List

NOTE: Items with Asterisk (*) must be shipped by common carrier.
Prices and Specifications are subject to change without notice.

Sea Snark SB102 & Super Snark SB114

Key No.	Quantity	Part No.	Description
1	1	74030*	Sea Snark Hull Only, Uncoated
1	1	74230*	Super Snark Hull Only, ABS Coated Blue & White
2	1	62420	Daggerboard, Wood
3	1	62760	Rudder Blade
4	1	P-74060	Tiller Assembly (74060 Tiller; 60100 Screw; 61010 Locknut)
5	1	P-62350	Mast Seat Assembly (62350 Mast Seat; 62410 4-Screws; 62510 4-Washers)
6	1	62250	Rudder "L" Pin
7	1	P-62380	Bow Eye Assembly (62380 Bow Eye; 62660 Locknut; 62870 2 Washers)
8	1	74030	Mast Sleeve
9	1	62380*	Mast (84")
10	1	74065*	Boom (120")
11	1	74065*	Spar (120")
12	1	40021	Sea Snark Sail, 45 Sq. Ft.
12	1	40022	Super Snark Sail, 45 Sq. Ft.
13	1	60060	Cotter Pin
14	1	P-62020	Rudder Head Assembly (62020 Rudder Head; 62560 Bolt; 61620 Washer; 62660 Locknut)
16	1	74080	Line Set
17	1	P-62010	Gudgeon Assembly (62010 Gudgeon; 60900 4-Screws)
18	1	P-61000	Eyestraps Assembly (61000 Eyestraps; 20840 2-Screws)
19	1	62430	Nylon Ring
20	1	P-62440	Boom Guide Assembly (62440 Boom Guide; 62490 2-Screws)
21	1	P-30680	Cleat Assembly (30680 Cleat; 31000 2-Screws; 31350 2-Locknuts; 62630 2-Washers)
22	1	62460	Mast Cap
26	1	74220	Well Cap, White (Super Snark)
41	1	62470	End Cap, White Plastic (Super Snark)
23	1	89100*	Sea Snark Sail Assembly (45 Sq. Ft. Sail) (40021 Sail; 62460 Mast Cap; 74070 Mast, Boom, Spar; 62510 2-Washers; 62480 Screw; 31220 Locknut; 74080 Line; 62470 4-End Caps; 62440 Boom Guide; 62490 2-Screws; 61000 4-Eyestraps; 20840 8-Screws; 62430 2-Nylon Rings)
23	1	89110*	Super Snark Sail Assembly (45 Sq. Ft. Sail) (40022 Sail; 62460 Mast Cap; 74070 Mast, Boom, Spar; 62510 2-Washers; 62480 Screw; 31220 Locknut; 74080 Line; 62470 4-End Caps; 62440 Boom Guide; 62490 2-Screws; 61000 4-Eyestraps; 20840 8-Screws; 62430 2-Nylon Rings)
25	1	P-62480	Connecting Bolt Assembly (62480 Screw; 31220 Locknut; 2-62510 Washers)
27	1	61990	Black Bumper (Rubber)
28	1	P-74280	Splash Deck Assembly (Optional) (74280 Splash Deck with Gasket; 61380 1-Screw Package)



SNARK BOATS

SailboatsToGo, LLC, Tel 978-263-7598, Jim@sailboatsToGo.com,
www.SailboatsToGo.com