



SailboatsToGo, LLC
 120 Avebury Circle
 Boxborough, MA 01719
 www.SailboatsToGo.com

SNARK BOATS

SUNCHASER II MODEL SB200 INFORMATION SHEET

TOOLS NEEDED FOR ASSEMBLY

- Flat Blade Screwdrivers
- Knife
- Needle Nose Pliers
- Adjustable Wrench or Socket Set
- Transparent Tape
- Hammer

NEED OF HELP?

If parts are missing or if you have questions concerning assembly, contact your dealer or call Snark Boats directly at

1-800-247-6275.

Replacement parts will generally be shipped within 24 hours.

Figure 1

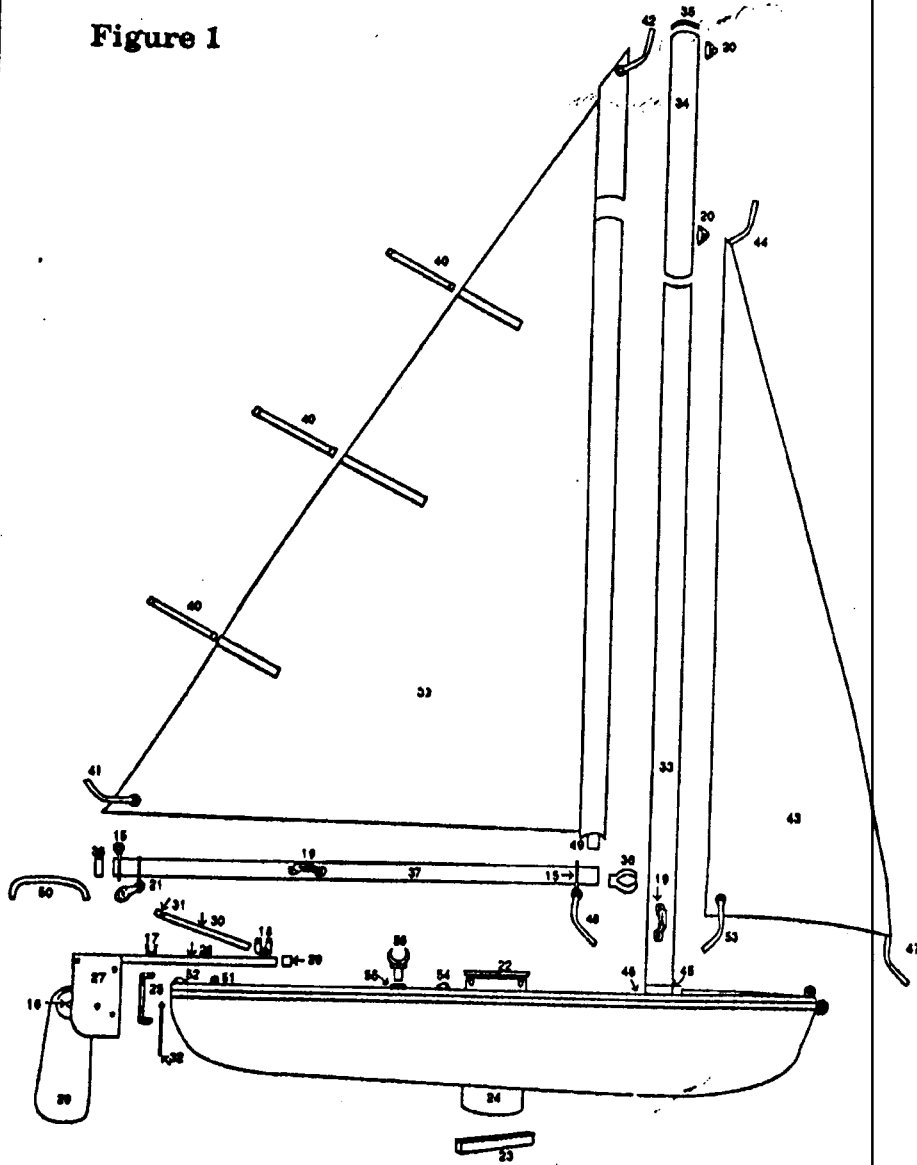

BEFORE USING YOUR SNARK BOAT, BE SURE TO READ THE OWNER'S RESPONSIBILITY SECTION ON PAGE 6.

SPECIFICATIONS

Length 12'
 Beam 4'8"
 Crew Capacity (Up to 6 people) 815 Lbs.

Total Combined Weight (People & Gear) .. 900 Lbs.
 Main Sail Area 80 Sq. Ft.
 Jib Sail Area 20 Sq. Ft.

ASSEMBLY

NOTE: Figure 1 illustrates the part numbers and their approximate locations, while figure 2 shows the hardware used during the assembly. The numbers on both figures correspond with the numbers in the assembly instructions.

DAGGERBOARD ASSEMBLY

1. The daggerboard top plate [22] and the daggerboard plug [23] are taped together for shipping. Unwrap the tape. Attach the daggerboard top plate [22] to the daggerboard [24] with two 2 1/4" flathead screws [6], washers [1] and hexnuts [2]. Hint: Holding the nut in place with a needle nose pliers makes it easier to tighten down the screw.

RUDDER ASSEMBLY

1. Attach the rudder pivot [25] to the rudder frame [27] with two 5/8" hexhead bolts [7] and medium locknuts [4]. The heads of the bolts go outside the rudder pivot and the locknuts go in the rudder frame.
2. Place a large rudder washer [16] on each side of the rudder [26], aligning the holes in each. Hint: You can keep the washers temporarily in place by taping them with Scotch® or other transparent tape. Slide the rudder/washers into the rudder frame [27] so that the large holes near the center of the rudder frame are aligned with the holes in the rudder/washers. Bolt them together with the 2" hexhead bolt [8] and large locknut [5]. (Make sure the washers are inside the rudder frame.) The nut should be snug but permit the rudder to 'kick up' if necessary.
3. Tie the precut 16" piece of thin line through the hole in the hinge pin [32] and the hole in the side of the rudder frame [27] using a figure 8 knot. Knot each end.
4. Locate the tiller [28]. Notice that there are three sets of holes on the tiller, but only the middle-most hole penetrates one side only. Screw the black plastic clip [17] into the middle hole with a 1/2" self-tapping screw [9].
5. Attach the tiller [28] to the rudder frame [27] using the 1 5/8" hexhead bolt [10] and medium locknut [4]. Make sure that the black plastic clip [17] is facing up before tightening the bolt. Don't overtighten the bolt since the tiller must be free to pivot. Put the square plastic end cap [29] (see figure 1) on the other end of the tiller.
6. Attach the hiking tiller pivot [18] to the last hole in the tiller [28] with a 1 1/2" truss-head screw [11] and medium locknut [4]. Attach the hiking tiller [30] to the hiking tiller pivot [18] with the 1 3/8" round-head screw [12] and medium locknut [4]. Place the round black plastic end cap [31] (see figure 1) on the hiking tiller.
7. Attach the rudder assembly to the hull with the rudder hinge pin [32].

MAST ASSEMBLY

1. Locate the longest mast section, the lower mast [33]. Attach a jam cleat [19] to the two holes at the lower end of the mast using two 1" panhead self-tapping screws [13]. NOTE: The pointed end of the 'V' shaped hole must point up the mast.
2. Slip the upper mast [34] into the lower mast, up to the collar. Insert the red mast cap [35] into the top of the upper mast [34].
3. Attach the two fair leads [20] to the two sets of holes in the upper mast with four 1" flathead self-tapping screws [14]. NOTE: The top screw will project through the side of the mast cap and will hold it securely in place. You may need to cut a notch out of the cap so that the mast fairlead will lay flat.

BOOM ASSEMBLY

1. Attach the other jam cleat [19] to the holes approximately one quarter of the way from the rear of the boom using two 1" panhead self-tapping screws [13]. NOTE: The pointed end of the 'V' shaped hole of the jam cleat must point toward the rear of the boom.
2. Slip the yoke [36] into the other end of the boom [37] (the end with only one hole in it). This is the front of the boom. Hold the yoke in place by attaching an eye bolt [15] and small locknut [3] in the holes provided. Note that the eye of the eye bolt is pointing down and that the jam cleat is on the right side of the boom as shown in Figure 3. Slip the black plastic cap [38] into the rear of the boom.
3. Attach the second eye bolt [15] and small locknut [3] to the hole in the boom that is closest to the black plastic cap. Note that the eye of this eye bolt is opposite of the eye bolt on the other end of the boom. (This one faces up.) See Figure 3.
4. In the next hole on the boom, install the pulley assembly [21] and small locknut [3]. Note that the pulley assembly faces down.

RIGGING THE SAILS

1. Lay the main sail [39] out flat on the ground. Install the battens [40] in the three batten pockets. NOTE: The smaller ends of the battens go in first. Each pocket has a piece of elastic sewn in the front end. As you insert the batten, firmly push the batten against this elastic so that the other end of the batten can be slipped under the flap at the rear of the pocket. The longer batten goes in the center pocket.

2. Slide the mast assembly (upper and lower mast) into the sleeve at the forward end of the main sail [39]. Turn the mast so that the fair leads [20] on the upper mast [34] point forward through the opening in the sleeve of the main sail.
3. Tie one end of the 4' piece of medium (#6) line to the grommet at the rear corner of the main sail using a bowline knot. (See sailing manual.) This line is called the outhaul [41].
4. Slip one end of the 35' piece of medium (#6) line through the fair lead [20] at the top of the mast and tie it to the grommet at the top of the sail using a bowline knot. (See sailing manual.) This line is called the main halyard [42]. (See figure 3.)
5. Thread the long line attached to the top of the jib sail [43] through the other fair lead [20]. (This fair lead projects through the opening in the sleeve of the main sail.) This line is called the jib halyard [44]. (See figure 3.)
6. Pull on both halyards [42 and 44] until the tops of each sail are near the fair leads.
7. While holding both halyards, carefully lift the mast and sail assembly straight up into the air and slip the mast into the mast step hole [45] in the deck. (This is called 'stepping' the mast.) Stepping may seem awkward at first, so practice it several times on dry land. CAUTION: Look up! Be sure there are no electric wires with which the mast may come in contact. Touching an electrical wire could cause a serious electrical shock. Twist the mast if necessary to ensure that the fair leads are forward and that the halyards are not twisted.
8. Now pull down on the main halyard [42] so that the main sail is at the top of the mast and cleat the main halyard [42] to one of the deck cleats [46]. Next pull down on the jib halyard [44] until the bottom of the jib is approximately 4" from the top of the boat. Cleat the jib halyard to the other deck cleat [46].
9. Tie the short line on the front edge of the jib sail to the bow eye, using a bowline knot. (See sailing manual.) This is known as the jib tie down [47].
10. Tie one end of the 2' piece of medium (#6) line to the eyebolt at the front of the boom. This line is called the downhaul [48]. (See figure 3.) Slip the yoke [36] at the front end of the boom through the loop [49] at the bottom forward edge of the main sail. Snap the yoke around the mast.
11. Cleat the downhaul [48] to the jam cleat on the lower mast [19]. NOTE: The downhaul is adjusted at the jam cleat to control the tension of the forward edge (luff) of the main sail. The harder the wind blows, the tighter the downhaul should be.
12. Thread the loose end of the outhaul [41] at the rear of the main sail through the eyebolt at the rear of the boom [37] and then forward along the boom to the jam cleat [19] and cleat it. You may wish to tie a figure 8 knot in the free end of this line. The outhaul is used to adjust the tension on the bottom edge (foot) of the main sail. The harder the wind blows, the tighter the outhaul should be.
13. Tie one end of the 25' large line, known as the main sheet [50], to the bull's eye fair lead [51] on the right rear side of the boat. A bowline or half hitch knot is recommended. (See the sailing manual.) Thread the main sheet through the pulley assembly on the boom [21], back down through the bull's eye fair lead on the left side of the boat, and across the large clam cleat [52]. Tie a figure 8 knot in the end of this line. (See sailing manual.) The main sheet controls the position of the main sail when sailing.
14. The remaining piece of medium line (20' piece) is called the jib sheet [53]. Tie the center of this line to the grommet at the rear of the jib sail using a half-hitch knot. Thread each of the other ends of the jib sheet through the small clam cleats [54] on each side of the boat near the oarlock sockets [55]. Tie figure 8 knots in the ends. The jib sheets control the jib sail. When sailing, one jib sheet is cleated while the other is loose. (See the sailing manual for details on sail trim.)
15. Check once more to make sure the fair leads on the mast [20] point forward and that there are no twists in the sleeve on the mast. If necessary, tip the boat over and make these adjustments. Now insert the daggerboard [24] part way down.
16. Admire the beautiful job you've done! Then sit down with your sailing manual, and in about 30 minutes, you'll be ready to sail.

ACCESSORIES INCLUDED WITH THE SUNCHASER

Included with the Sunchaser II are oarlocks [56] and a daggerboard plug [23]. When the sailing rig is removed from the Sunchaser, it can be used as a standard boat which can accommodate a motor rated up to six horsepower. Replace the daggerboard with the daggerboard plug and add the oarlocks (if desired) when using the boat in this manner.

FIGURE 2

These Parts Are Not Drawn To Scale

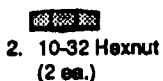

3. 10-24 Small Locknut (3 ea.)

4. 1/4-20 Med. Locknut (5 ea.)

5. 3/8-16 Large Locknut (1 ea.)



6. 10-32 x2 1/4" Flat Head Screw (2 ea.)

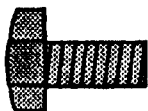

7. 1/4-20 x 5/8" Hexhead Bolts (2 ea.)



8. 3/8-16x2" Hexhead Bolt (1 ea.)



9. 7x1/2" Oval Head Self Tapping Screw (1 ea.)



10. 1/4-20x1 5/8" Hex Head Bolt (1 ea.)

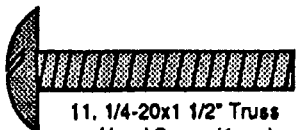

11. 1/4-20x1 1/2" Truss Head Screw (1 ea.)



12. 1/4-20x1 3/8" Round Head Screw (1 ea.)

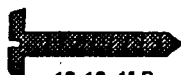

13. 10x1" Pan Head Self Tapping Screw (4 ea.)

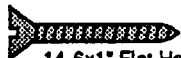

14. 6x1" Flat Head Self Tapping Screws (4 ea.)

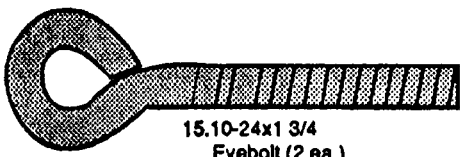

15. 10-24x1 3/4" Eyebolt (2 ea.)

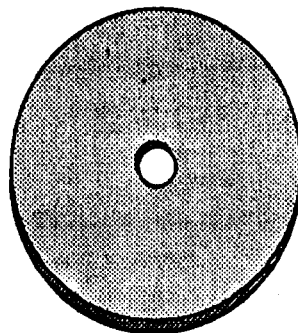

16. Rudder Washer (2 ea.)



17. Black Plastic Clip (1 ea.)

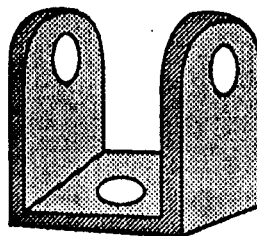

18. Hiking Tiller Pivot (1 ea.)



19. Jam Cleat (2 ea.)

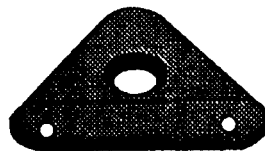

20. Fair Lead (2 ea.)

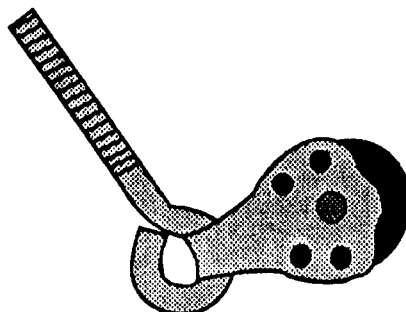

21. Pulley Assembly (1 ea.)

FIGURE 3

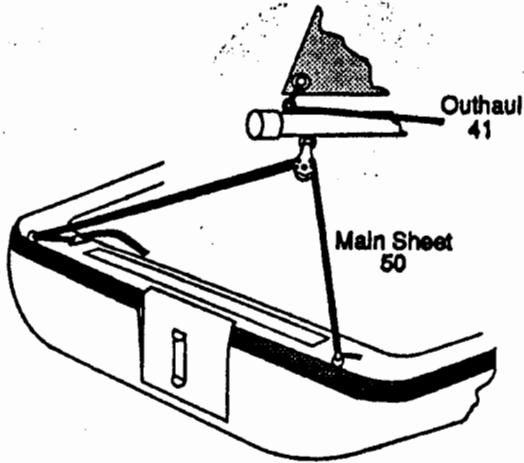

BACK OF THE BOAT

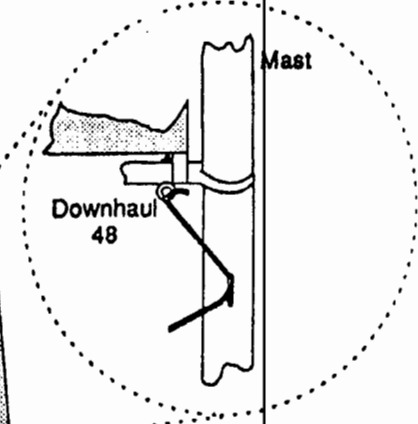
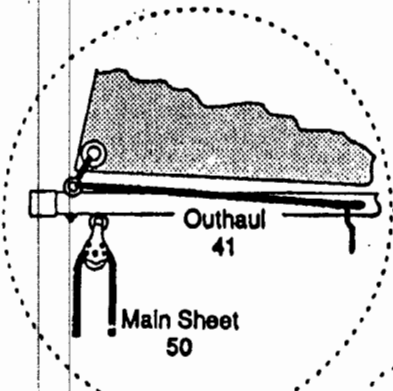
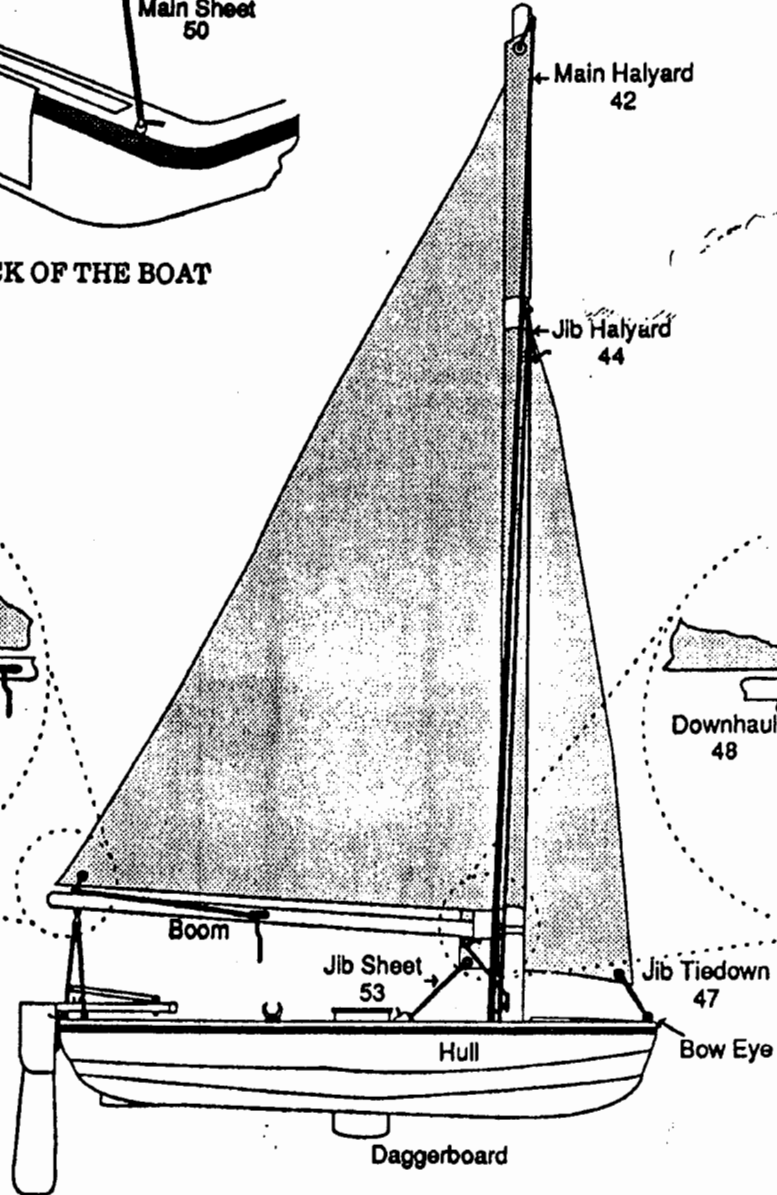

SAFETY – OWNER'S RESPONSIBILITY

BE SURE TO READ THE FOLLOWING BEFORE LAUNCHING YOUR SAILBOAT

1. Before operating your boat, read the Snark Sailing Manual carefully and be thoroughly familiar with the rules for safe operation.
2. Do not overload your boat. Capacities are clearly stated on the Capacity Information Plate on the boat.
3. The Sunchaser is a small boat and caution must always be used, particularly when operating on open bodies of water where conditions can be unexpectedly severe. Never sail in severe weather. Small craft warnings mean just that; if your boat becomes difficult to control, head for shore.
4. At first, try sailing the boat when winds are gentle (wind velocity of 5 to 10 miles per hour). Do not attempt to sail the Snark at velocities over 20 mph unless you are very experienced at sailing the boat.
5. Each person on the boat should wear a Coast Guard-approved personal flotation jacket.
6. Check with the local authorities for regulations governing registration and operation of your boat. In addition to life jackets, they may also require that you carry a whistle, paddle, container for bailing water, or other safety items.
7. Since the Sunchaser is unsinkable, capsizing is not a big concern. If the boat capsizes and is on its side, simply grasp the daggerboard and push until the boat rights itself. If the boat flips completely so the daggerboard is facing the sky, push on the side of the boat with your feet until the boat rights itself. Note: The mainsheet must be uncleated so that the water can run out of the sail while righting the boat. Once the boat is righted, reboard it over the transom (rear of the boat). If you are unable to reboard the boat, stay with it until help arrives.

TRANSPORTING YOUR SAILBOAT

Cartopping is an easy and inexpensive way to transport your boat. Use a good quality cartop carrier. (If you need a suitable roof rack, you may order one directly from Snark at 1-800-247-6275. Call for a description and price.) The Sunchaser should be positioned upside down on the carrier so the overhang on all sides is equal. Paddings should be placed between the gunnels (edges of the boat) and the cartop carrier to prevent the effects of rubbing. The straps provided with your carrier should be secured to provide 100% of the holding of the boat. Safety lines may be tied from the bow eye to the front bumper and from the rudder bracket to the rear bumper. These, however, are safety lines only and do not provide adequate security by themselves. Tie all lines snugly—not tightly. Cartop safely and check the straps frequently.

If you decide to trailer your Sunchaser, it should be on a bar or pad type trailer. **DO NOT USE A ROLLER TYPE TRAILER**, as the rollers do not spread out the weight which could damage the hull.

CARE AND MAINTENANCE

1. Your boat should be kept inside or covered when not in use. Avoid long periods of exposure to direct sunlight or weather to avoid discoloration.
2. The Armour Clad construction is exceptionally strong, but like other boat construction materials, it is not indestructible. The Sunchaser will absorb impact exceptionally well. However, a severe impact can cause a fracture. The core of the Sunchaser is constructed of EPS foam. The outer layer is made of ABS. Gasoline or oil spills will damage the EPS foam, and repairs should be made to it immediately using the Epoxy Repair Kit BA302. Repairs to the outer ABS skin can be made with the Armour Clad Repair Kit 83040. Both repair kits are available from Snark Boats.
3. Cleaning your Snark: Do not use solvents, detergents, polishes, waxes, or any other cleaners or protectants on your boat since these products can damage it. Use a soft brush and mild soap only to clean your boat. Suntan oils, cosmetics, and grease should be removed promptly to deter permanent stains.



SailboatsToGo, LLC
120 Avebury Circle
Boxborough, MA 01719
www.SailboatsToGo.com



SNARK BOATS

SUNCHASER II SB200 REPLACEMENT PARTS PRICE LIST

Note: Items with an asterisk (*) must be shipped by common carrier.

Prices and specifications are subject to change without notice.

Key No.	Part No.	Description
5	133	Rudder Lock Nut
8	134	Rudder Bolt
15	P-127	Boom Eyebolt & Nut (127 Eyebolt; 31550 Locknut)
18	110	Rudder Washers
17	P-180	Hiking Clip Assembly (180 Clip; 31370 Screw)
18	P-171	Pivot Assembly (171 Pivot, 177 1-Screw, 31220-1 Locknut)
19	P-152	Jam Cleat Assembly (152 Jam Cleat; 140 2-Screws)
20	P-278	Mast Fair Lead Assembly (278 Fairlead; 31370 2-Screws)
21	P-210	Pulley Assembly (210 Pulley; 127 Eyebolt; 31550 Locknut)
22	P-117	Daggerboard Top Plate (138 2-Screws, 272 2-Washers)
23	234	Daggerboard Plug
24	P-116-1	Daggerboard Assembly (116-1 Daggerboard; 117 Top Plate; 138 2-Screws; 190 2-Nuts; 272 2-Washers)
25	P-103	Rudder Pivot Assembly (103 Rudder Pivot; 31220 2-Locknuts; 136 2-Bolts)
28	116-2	Rudder Blade
27	114	Rudder Frame
28	P-157	Tiller Assembly (157 Tiller; 155 Cap; 135 Screw; 31220 Locknut)
30	P-166	Hiking Tiller Assembly (166 Hiking Tiller; 176 1-Screw; 31220 1-Locknut; 62470 Cap)
32	151	Rudder Hinge Assembly (Rudder Hinge Pin; #4 (16") Line)
33	115-1*	Lower Mast (144")
34	115-2*	Upper Mast (104")
35	283	Plastic Mast Cap
36	31790	Boom Yoke
37	115-3*	Boom (110")
38	145	Plastic Boom Cap
39	40028	Main Sail (80 Sq. Ft.) (Color of Sail May Vary)
40	B-40028	Battens (Set of 3)
41		#6 Line Set (35', 20', 4', 2')
43	J-40028	Jib Sail (20 Sq. Ft.) (Color of Sail May Vary)
45	P-143	Mast Ring Assembly (143 Mast Ring, 141 2-Screws)
48	P-30680	Cleat Assembly (30680 Cleat, 141 2-Screws)
50	150	#12 Line (25')
51	P-29400	Bull's Eye Fair Lead Assembly (29400 Bull's Eye Fair Lead; 2-Screws)
52	P-40122	Large Stern Clam Cleat Assembly (40122 Clam Cleat; 2 Screws)
54	P-63630	Gunnel Clam Cleat Assembly (63630 Clam Cleat; 32130 2-Screws)
55	P-30900	Oarlock Socket Assembly (30900 Oarlock Socket; 139 2-Screws)
58	30910	Oarlock Horns
	H-SB200*	Hull Only
	P-89190*	Complete Sail and Rigging
	212	Hatch Cover (Left or Right)
	83010	Epoxy Repair Kit for Inner Foam
	83040	Armour Clad Repair Kit (Available in red, yellow, white, or blue)
	00340	Steel roof rack for cars and vans with or without rain gutters (Expandable from 44" to 76")

